

Paint Mixing Machine



油漆搅拌机

Installation and Operation Manual

安装使用说明书

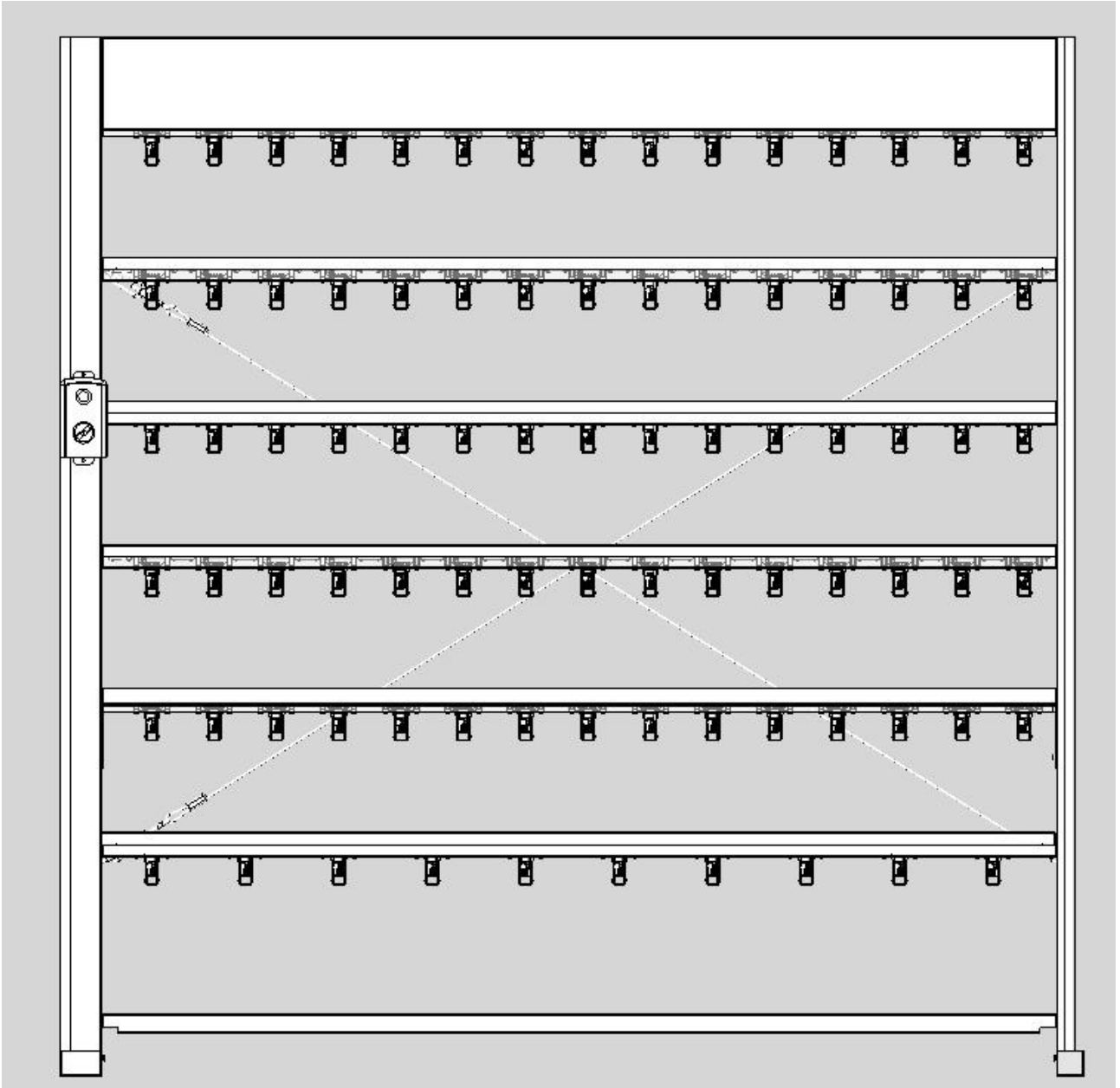

Please read the manual before using.
请使用前详细阅读此说明书

Contents

1.	Introduction.....	3
2.	Precaution:	4
3.	Product Specifications.....	4
4.	Electrical Principle Chart.....	5
5.	Installation.....	5
6.	Test Running.....	10
7.	Operation.....	10
8.	Repair & Maintenance.....	11

目录

1.	绪论.....	12
2.	注意事项:	13
3.	产品规格.....	13
4.	电气原理图.....	14
5.	安装.....	14
6.	试机.....	18
7.	使用.....	18
8.	故障排除.....	19

1. Introduction

Thanks for purchasing our products.

Different from traditional paint mixing machine, our products are brand-new mode that worldwide originally developed, which will bring you much convenience in installation and operation. Please read the manual in details and begin installation and operation after having detail knowledge regarding safety and operation.

Though products specifications are diversified, installation and operation method are basically similar, so we only illustrate for a general structure mixing machine. Continuing to improve and perfect the product is our consistent aim, SINOTINT reserves the right to improve and update products, and the information in the manual is subject to change without additional notice.

شهادة - Certificate - 증명서 - 證明書 - Сертификат



Certificate of Compliance

No. 0P180921.ZSMTS25
 Technical Construction File no. SCC(18)-41208A-118-10-LVD/MD

Certificate's Holder:	ZHENGZHOU SANHUI MACHINERY & EQUIPMENT CO., LTD. No.40, 5F, Building 11, No.338 Lianhua Street, HI-NEW TECH ZONE, Zhengzhou, Henan, P.R. China
Certification ECM Mark:	
Product: Model(s):	Paint Mixing Machine CE-MN
Verification to:	Standard: EN ISO 12100:2010, EN 60204-1:2006+A1:2009+AC:2010 related to CE Directive(s): 2006/42/EC (Machinery) 2014/35/EU (Low Voltage)

Remark: The product(s) has been verified on a voluntary basis. The product(s) satisfies the requirements of the Certification Mark of ECM, in reference to the above listed Standard(s). The above Compliance Mark can be affixed on the product(s) accordingly to the ECM regulation about its release and its use. The regulation can be found at www.entecerma.it. This Certificate of Compliance can be checked for validity at www.entecerma.it.
 This verification doesn't imply assessment of the production of the product(s).

Additional information, clarification about the CE Marking:
 We attest that a TCF for the CE Marking process is in place. Whereas the Manufacturer is Responsible to start the CE Marking Certification Procedure and to perform all the necessary activities, as required by the Directive before placing the CE Mark on the product(s).



Date of issue 21 September 2018

Chief Manager
Marta Morina



Expiry date 20 September 2023

Deputy Manager
Amanda Payne



Ente Certificazione Macchine Srl
 Via Ca' Bella, 243 - Loc. Castello di Serravalle - 40053 Valsamoggia (BO) - ITALY
 ☎ +39 051 6705141 📠 +39 051 6705156 ✉ info@entecerma.it 🌐 www.entecerma.it

2. Precaution:

Please read the precaution carefully before installation.

- 1) Check if the voltage and frequency are accordance with what on the nameplate that stuck on the left side plate.
- 2) The machine must be placed on leveling solid ground.
- 3) The machine should be placed in dry and well-ventilated space. Do not operate it in dangerous occasion which may cause explosion.
- 4) The machine should be equipped with well grounding. Do not assemble or disassemble the machine without permission.
- 5) Shake the paint well in the tins before placing in the machine.
- 6) All maintenance work must be done after both machine halt and power supply disconnected. NO maintenance without disconnect power supply or during working.
- 7) Do not use inflammable liquid to clean the machine.
- 8) Children are forbidden to approach the machine.
- 9) Single mixing time should be no more than 30 minutes, and each interval of no less than 20 minutes.
- 10) Motor will get hot during working, and be careful during repair.

3. Product Specifications

Standard configuration

	Standard Configuration	Shelves	Shelves for liter can+Shelves for gallon can	Positions for gallon cans	Total positions	Shape Size(mm) (L×W×H)
Series	MN-8	5	3+2	16	52	1610×500×2000
		5	4+1	8	56	
		6	4+2	16	64	
		6	5+1	8	68	
	MN-10	5	3+2	20	65	1970×500×2000
		5	4+1	10	70	
		6	4+2	20	80	
		6	5+1	10	85	
	MN-12	5	3+2	24	72	2330×500×2000
		5	4+1	12	84	
		6	4+2	24	96	
		6	5+1	12	102	

Remarks : power of single motor is 50W, thus total power of the mixing machine is shelves number ×50w.

Total shelves are two kinds: 5 shelves and 6 shelves. Shelves for big cans(2.5-4L) can be 1 shelf or 2 shelves.

Remarks: Mixing function of the first and second bottom mixing shelf can be removed and change for storage and displaying paint cans.

4. Electrical Principle Chart

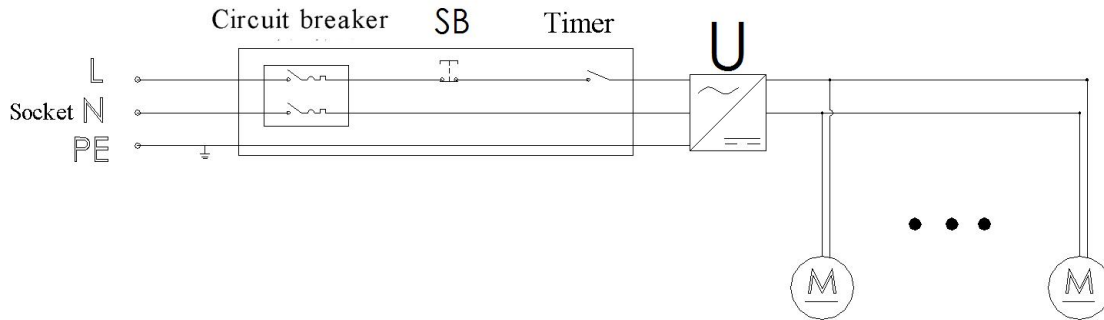

5. Installation

Open the carton box, check the articles and quantity inside according to the packing list. Take out tools and accessories, then install the machine following the manual.

Remarks: pictures shows in the manual are of standard equipment, if different, install the spare parts in the corresponding place.

For machine with two gallon cans shelves, please check the followed assembly introduction. The position for gallon cans are showed in Picture 5.4.

For machine with only one gallon cans shelf, assemble it in the right position as picture shows, and then change the base plate to the upward holes.

5.1. Align the holes of left base beam with the holes on the bottom of the left side plate, fix with 3 pcs of M6×12 screws. Assemble the right base beam similarly.

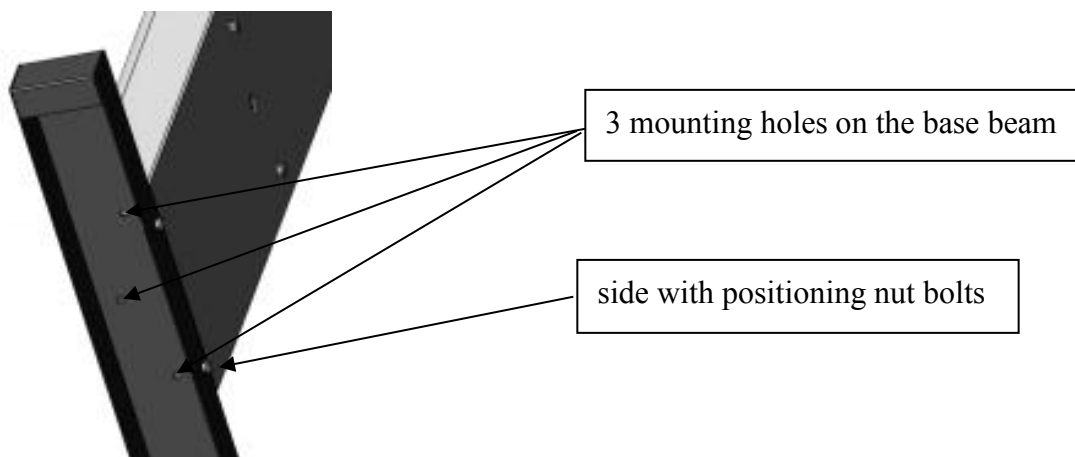

5.2.Assemble the base plate: raise the assembled left & right side plates, keep a distance of a base plate between the two side plates. Put the base plate onto the positioning screws on the side plates, press it downward into place.

Remarks: for machine with 1 gallon can shelf, the gallon can shelf need to be mounted on the positioning nut bolts on side plates. For machine with 2 gallon shelves, the base gallon shelf need to be mounted on the positioning nut bolts on the bottom beams.

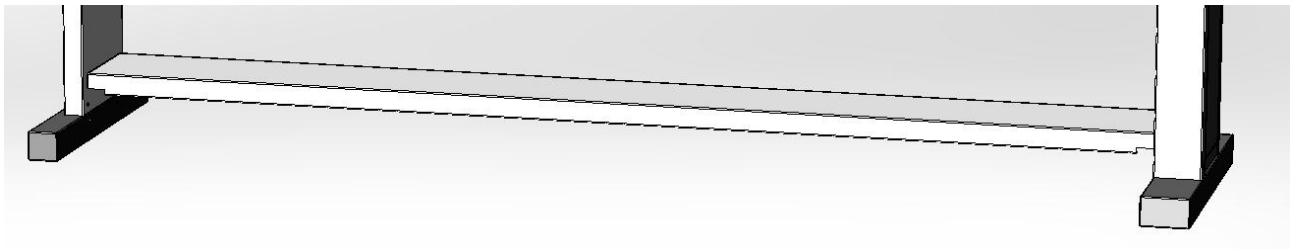
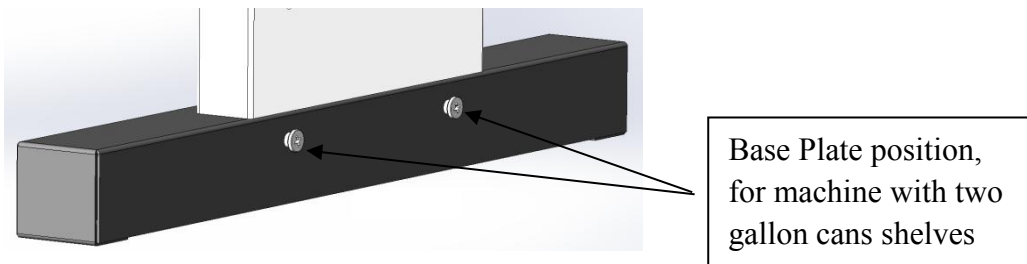
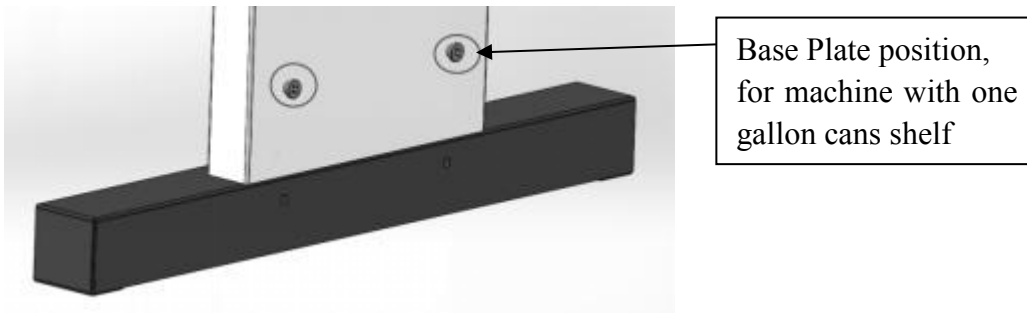

5.3 Install mixing shelf for Big Cans(Gallon cans). The end with round hole need to be on left hand, place downwards the groove of two sides into the nut bolts on the side plate until it arrives at the correct position.

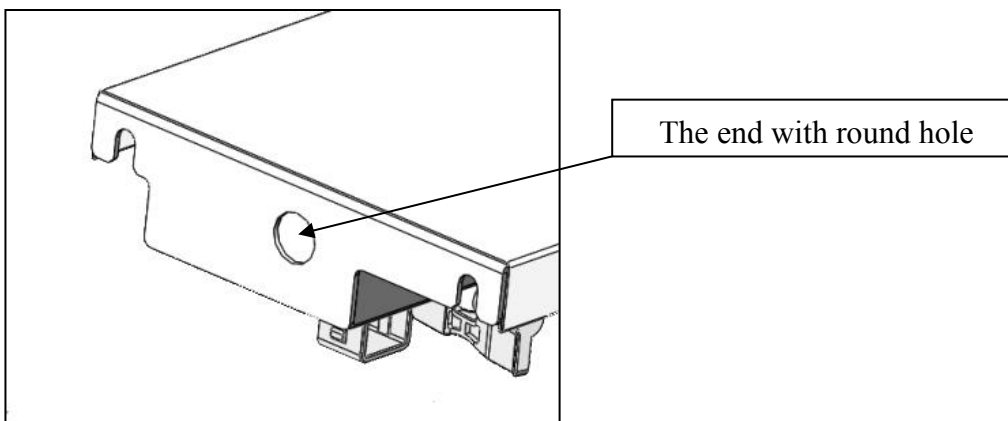

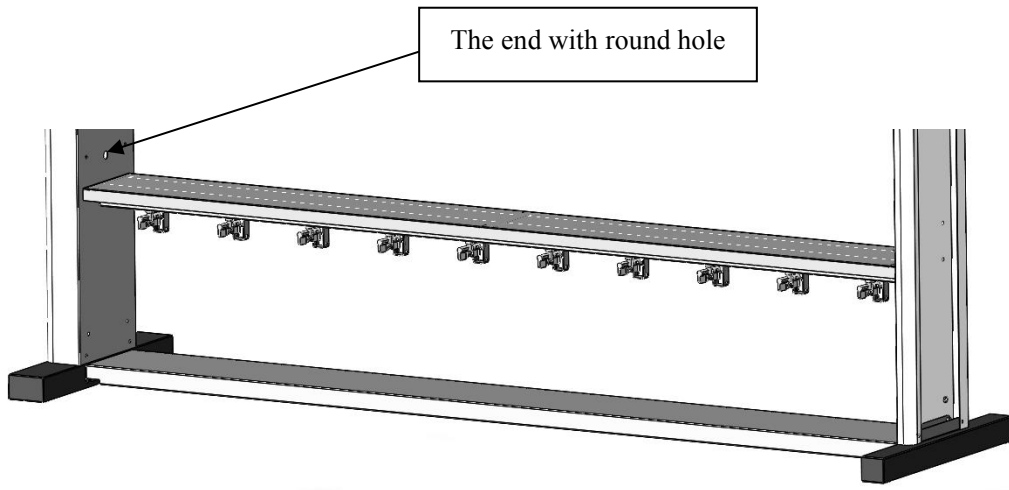

5.4 Position for mixing shelves and base plate

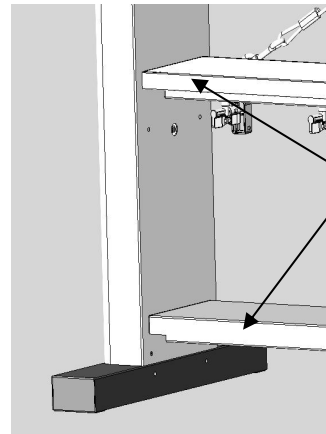
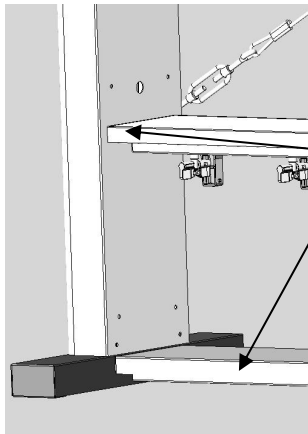

5.5 Install mixing shelf for Small Cans(liter cans). The end with round hole need to be on left hand, place downwards the groove of two sides into the nut bolts on the side plate until it arrives at the correct position.

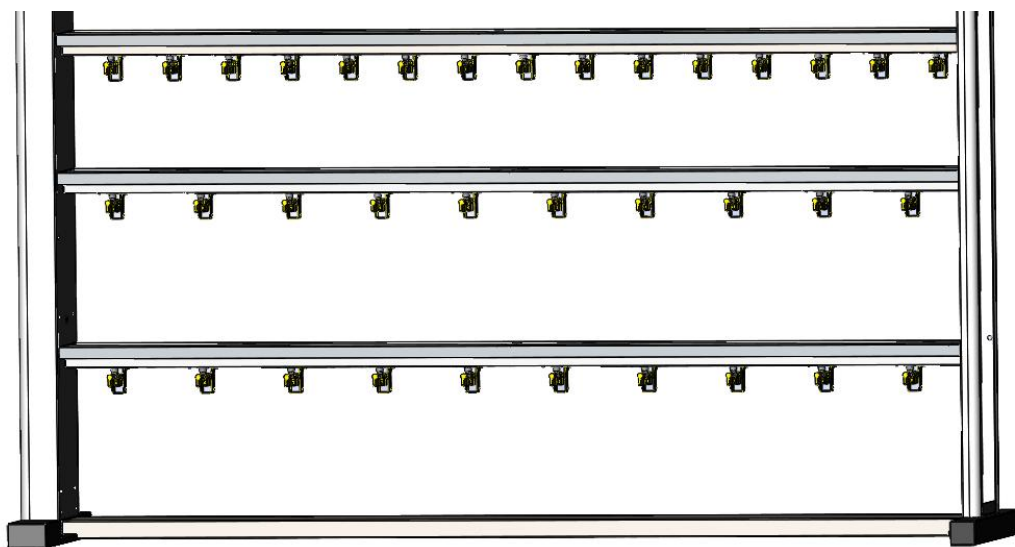

5.6 Assemble the connecting shaft: open the mixing shelf shield, insert the end with small boss to the round hole on left side plate, so it can connect to the motor inside. (Remarks: align the slotted surface to insert)

Push the spring to left so it can be stuck to the face gear shaft in the mixing shelf. Assemble the other connecting shaft for each shelf in the same way.

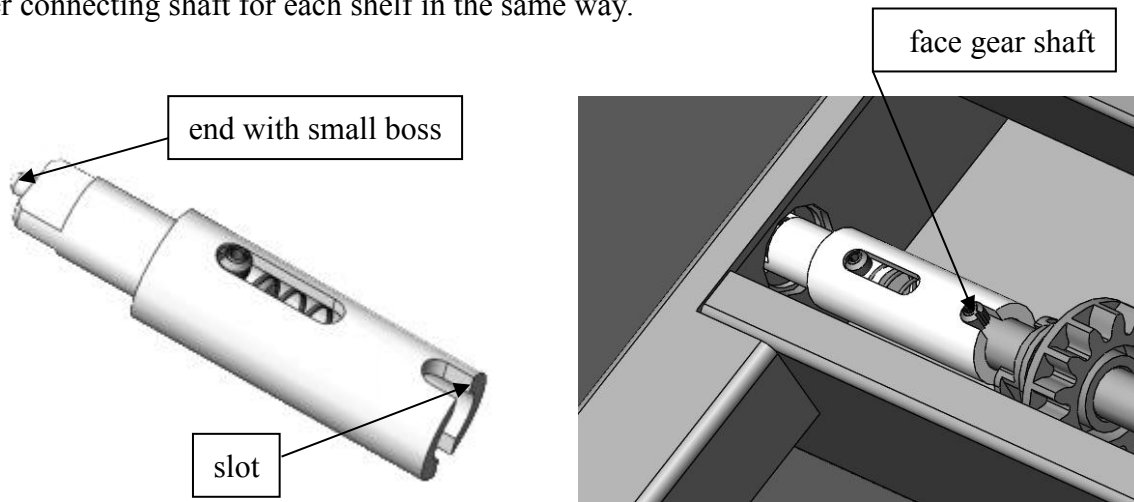

5.7 Install header board: insert the slot of the header board to the positioning screw, and press downward to the right place.

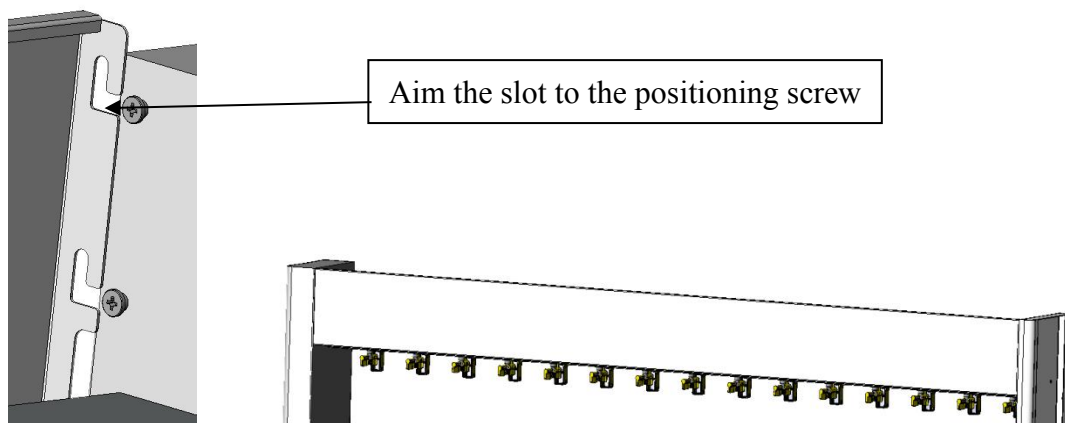

5.8 As the picture shows below, assemble the pulling strip with Allen Key. Screw two spiral buckles to tight the pulling strip, making sure that the machine stands stably.

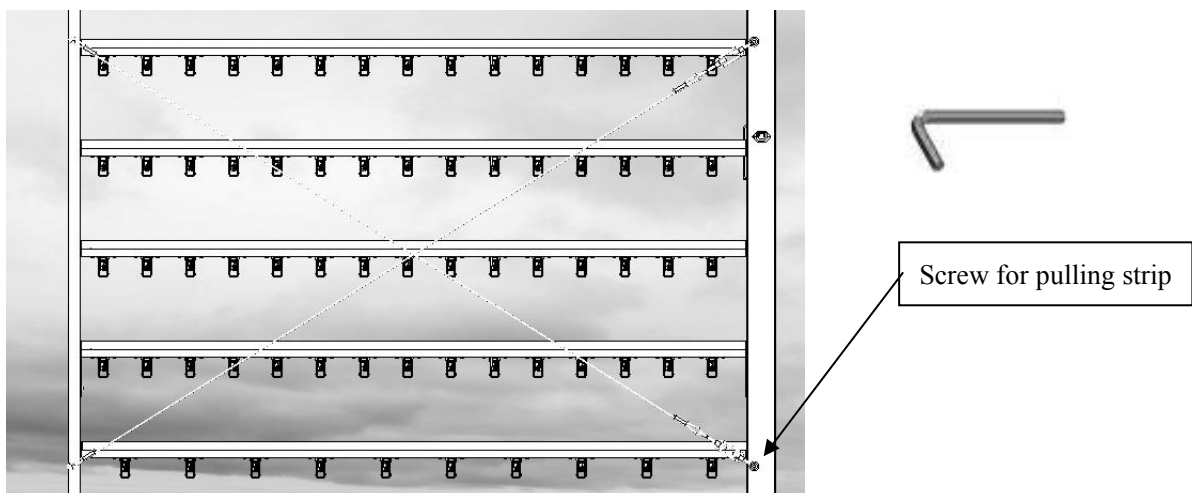

5.9 Install the working table. If there was a working table needs to be installed, install both two sides supporting racks onto the mixing shelves with “working table top” mark. **Do not tighten the screws first.** Install the working table onto the left and right supporting racks and tighten the screws. Remarks that usually the working table is installed at the second layer counted from the bottom up.

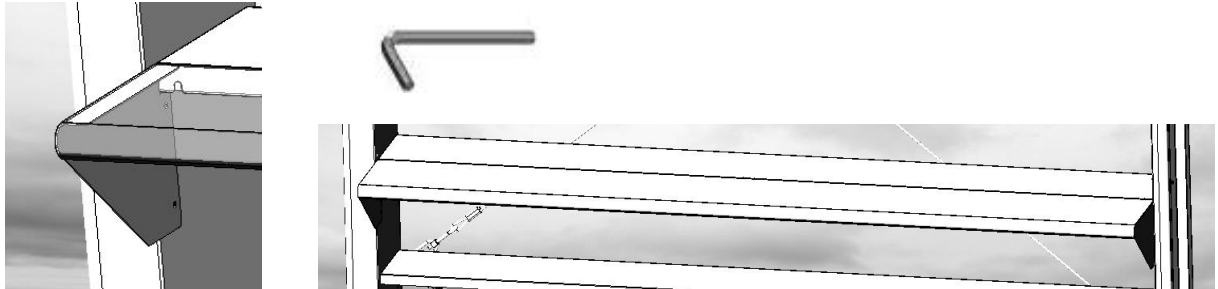

5.10 Align the two mounting holes of the control box seat plate with the upper and lower screws on the left side plate. Insert from the big hole end and turn slightly anticlockwise, fix the control box with Allen Key. Connect the control box plug to the male plug on the back of left side plate.

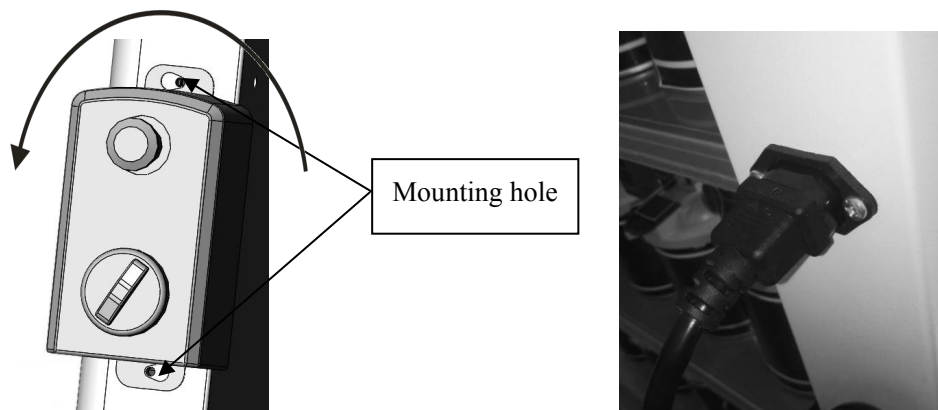

5.11 Pull down the plastic locator on the mixing shelf, and make it stuck in the slot until a “click” is heard.

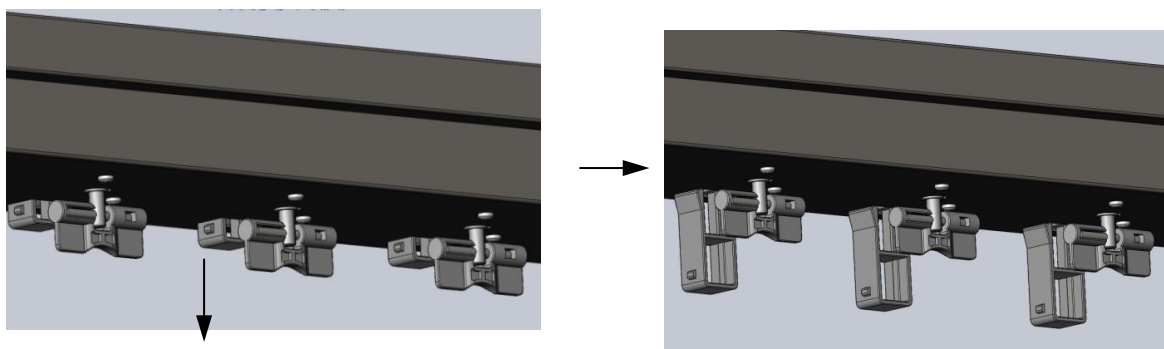

Now the installation has been finished.

6. Test Running

1. Connect power supply, push upward the small circuit breaker on the control box.
2. Rotate Timer Knob and set the Mixing Time, maximum is 15 minutes. When the setting time exhausts, the machine will stop work automatically. If you want to stop the machine during its working, you can rotate Timer Knob at anticlockwise sense to “OFF” .

Remarks: if there was abnormal noise when the mixing machine start to work, please press the Emergency Stop button, the machine will stop working. Once the abnormality is solved, turn the Emergency Stop Button clockwise, and it will be powered on.



7. Operation

Please Remarks: Shake the paint well in the cans before placing into the machine.

When placing the cans into the mixing machine, insert the limit stop collar (as picture shows) of the mixing lids to the locator hole.

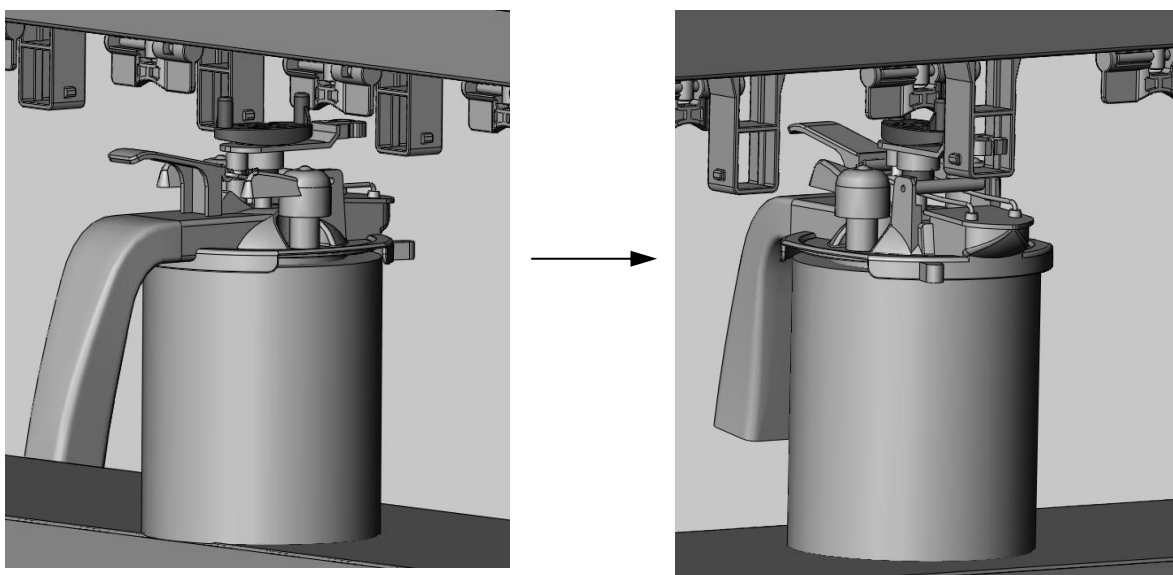

Rotate the timer knob as per the time you set, and then the mixing machine will work.

8. Repair & Maintenance

Symptoms	Causation	Troubles Shooting
Motor does not work Or hard to transfer the load	No power supply	Check the socket and the power cord, make sure that there is power supply to the Control Box.
	Power plug loosed	Open the left side plate and mixing shelf, and connect the plug again.
	Miniature circuit breaker switched off	Switch on the miniature circuit breaker.
	Voltage is too low	Measure if the voltage is located within 220V $\pm 5\%$; If not, equip with a regulator n.
	Power adaptor is damaged.	Change a new adaptor and connect the power supply.
	Motor is damaged	Remove the damaged motor, install a new one, and connect to the socket.
	Emergency Stop Button is power off	Turn the Emergency Stop Button clockwise, and it will be powered on.
Motor works but mixing shelves doesn't work	The main shelf connecting shaft is off	Open the mixing shelf, check whether all the shelf connecting shafts is well installed in place. If not,adjust it.

⚠ All maintenance work must be done after both machine halt and power supply disconnected. NO maintenance without disconnect power supply or during working.

1. 绪论

感谢您购买本公司的产品。

本公司生产的搅拌机是世界全新型搅拌机，与传统形式有很大不同，安装和使用会使您更加方便。为是您更加正确使用本产品，请仔细阅读说明书，了解安全和操作知识以后，方可安装和操作搅拌机。

本公司的产品规格较多，但安装方法和使用方式都是基本类同，所以本公司只是针对一般结构形式搅拌机进行了说明。同时持续改进和完善产品是本公司的一贯宗旨，郑州三惠机械设备有限公司保有随时对产品进行改进、更新的权力，如手册中的信息有变动，恕不另行通知。

شهادة – 증명서 – Certificat – 證明書 – Сертификат – Certificate

Certificate of Compliance



No. 0P180921.ZSMTS25

Technical Construction File no. SCC(18)-41208A-118-10-LVD/MD

Certificate's
Holder:

ZHENGZHOU SANHUI MACHINERY &
EQUIPMENT CO., LTD.
No.40, 5F, Building 11, No.338 Lianhua Street,
HI-NEW TECH ZONE, Zhengzhou, Henan, P.R. China

Certification ECM
Mark:



Product:
Model(s):

Paint Mixing Machine
CE-MN

Verification to:

Standard:
EN ISO 12100:2010,
EN 60204-1:2006+A1:2009+AC:2010

related to CE Directive(s):
2006/42/EC (Machinery)
2014/35/EU (Low Voltage)

Remark: The product(s) has been verified on a voluntary basis. The product(s) satisfies the requirements of the Certification Mark of ECM, in reference to the above listed Standard(s). The above Compliance Mark can be affixed on the product(s) accordingly to the ECM regulation about its release and its use. The regulation can be found at www.entecerma.it. This Certificate of Compliance can be checked for validity at www.entecerma.it

This verification doesn't imply assessment of the production of the product(s).

Additional information, clarification about the **CE** Marking:



We attest that a TCF for the **CE** Marking process is in place. Whereas the Manufacturer is Responsible to start the **CE Marking Certification Procedure** and to perform all the necessary activities, as required by the Directive before placing the **CE** Mark on the product(s).

Date of issue 21 September 2018

Expiry date 20 September 2023

Chief Manager
Marta Morina

Deputy Manager
Amanda Payne

Ente Certificazione Macchine Srl

Via Ca' Bella, 243 – Loc. Castello di Serravalle – 40053 Valsamoggia (BO) - ITALY
☎ +39 051 6705141 📠 +39 051 6705156 ✉ info@entecerma.it 🌐 www.entecerma.it

2. 注意事项:

在安装设备之前，请仔细阅读此注意事项

- 1) 检查电源电压频率与设备电动机的铭牌上的数据是否相符合。
- 2) 油漆搅拌机应安装在平整坚实的地面上。
- 3) 油漆搅拌机应安装在干燥、通风良好的地方。禁止在防爆的危险场合使用。
- 4) 设备必须有良好的接地线。不得私自拆装该设备。
- 5) 油漆桶在放入设备前必须进行充分底搅拌。
- 6) 维修工作必须首先停机并拔掉电源线，严禁未拔掉插头或运转时进行维护。
- 7) 不要用可燃性液体来清洁设备。
- 8) 不要让儿童接近该设备。
- 9) 单次搅拌时间不要超过 30 分钟，每次间隔时间不要小于 20 分钟。
- 10) 电机工作时发热，维修时小心烫手。

3. 产品规格

标准型搅拌机参数表:

	系列	搅拌层数				外形尺寸(mm) (长×宽×高)
			小+大	大头数量	总头数	
标准型 搅拌机 系列	MN-8 系列	5	3+2	16	52	1610×500×2000
		5	4+1	8	56	
		6	4+2	16	64	
		6	5+1	8	68	
标准型 搅拌机 系列	MN-10 系列	5	3+2	20	65	1970×500×2000
		5	4+1	10	70	
		6	4+2	20	80	
		6	5+1	10	85	
标准型 搅拌机 系列	MN-12 系列	5	3+2	24	72	2330×500×2000
		5	4+1	12	84	
		6	4+2	24	96	
		6	5+1	12	102	

单搅拌电机功率为 50W，整机功率=层数×50（W）。

搅拌机总层数为 6 层，大桶搅拌层数一般为 1、2 层。

另：可以不要 1、2 搅拌层更换为底层架板作为货架储藏或展示油漆桶。

4. 电气原理图

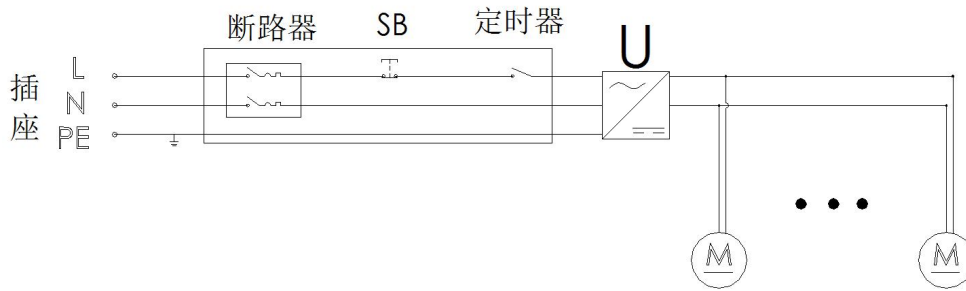

5. 安装

打开包装箱，根据装箱单清点物品及数量。取出装机工具、装机配件按此说明书介绍安装设备。

注：本说明书所使用图片为标准配置，如有不同请安装在相应的挂件上即可。

两层大桶的安装方法如下面的方法安装到位即可。最下面一层大桶位置如图 5.4 的两层大桶安装位置

一层大桶的安装方法如下面的方法安装完成后，需要将底板换到如图 5.4 的一层大桶安装位置

5.1. 左右底梁安装：将左底梁的孔对齐左侧板底部的孔，用 3 个 M6*12 的螺丝固定同理安装右侧板。

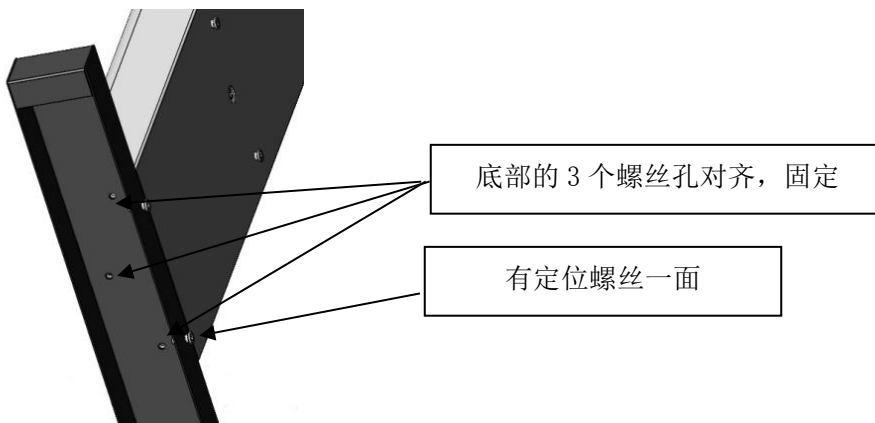

5.2. 底板的安装：将装好的左右侧板竖起，中间需要调整间距能放下底板为宜，将底板挂到侧板下面已装好的定位螺丝上，向下压安装到位。注：1 层大桶安装到侧板定位螺丝上，2 层大桶安装到底梁定位螺丝上。

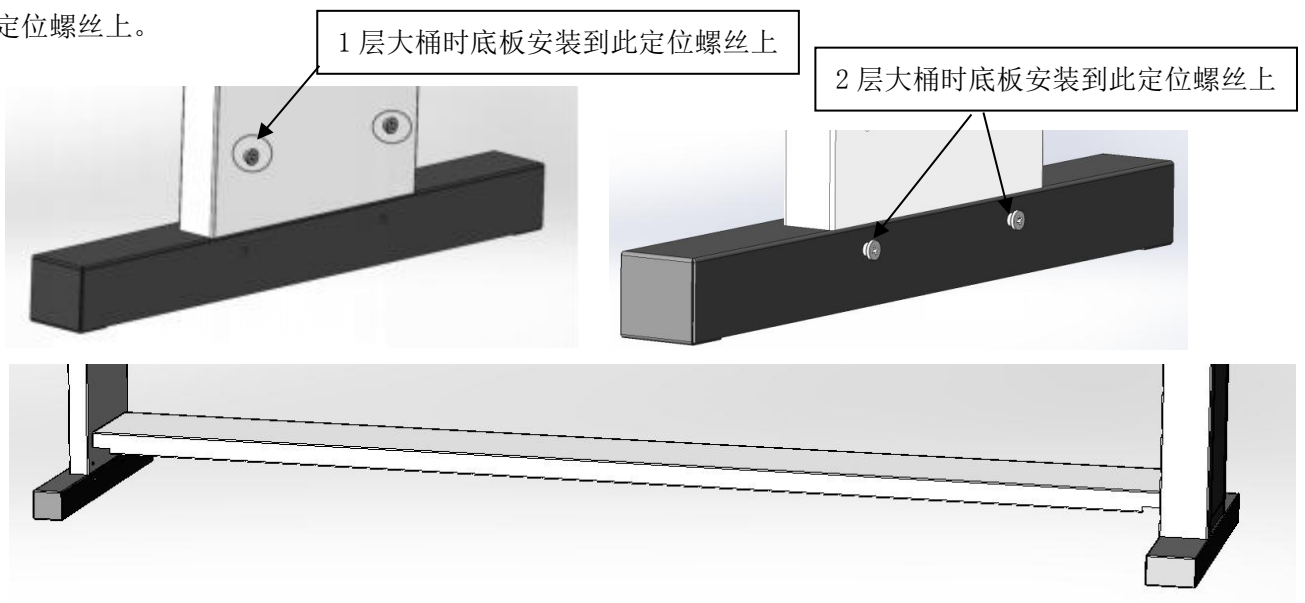

5.3. 大桶架板安装，大桶架板有圆孔的一端向左，将两侧面的槽口插入侧板上的螺钉中，下压到位。

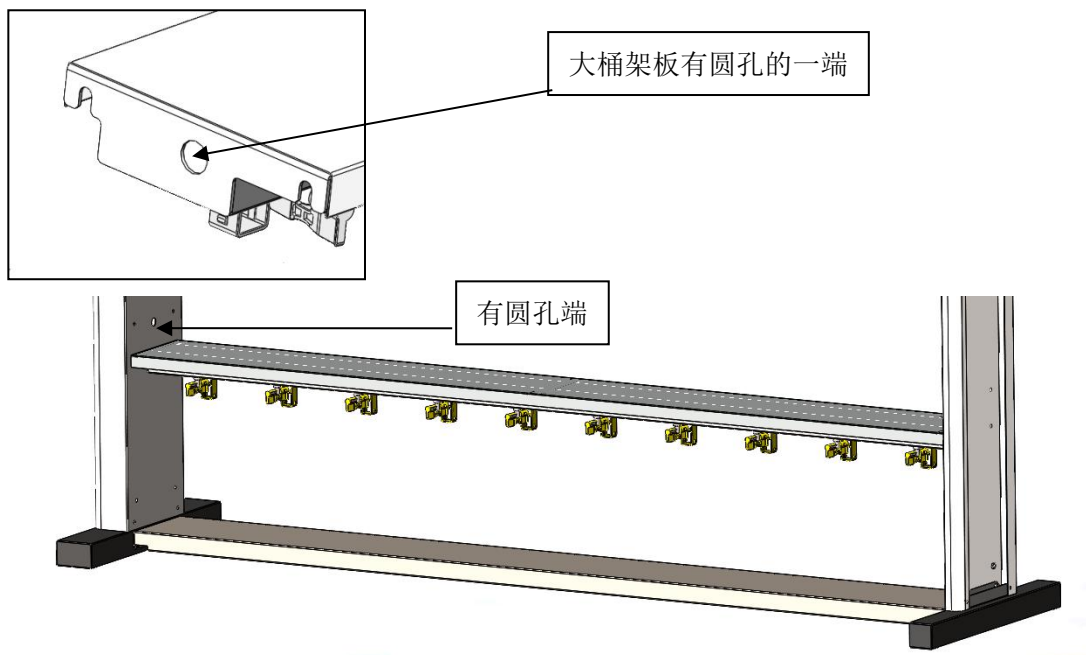

5.4. 架板和底板安装位置

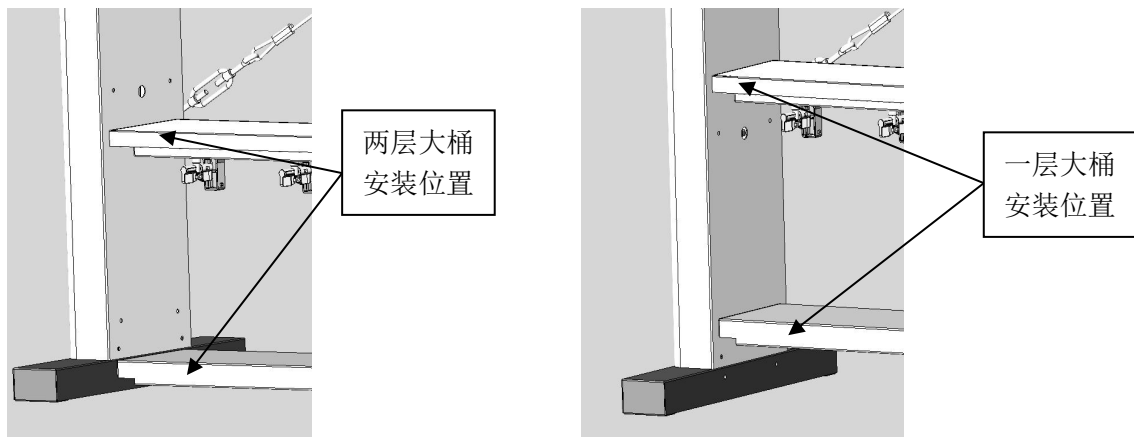

5.5. 小桶架板安装，小桶架板有圆孔的一端向左，将两侧面槽口插入侧板上的螺钉上，下压到位。

同理将其他小桶架板安装到位。

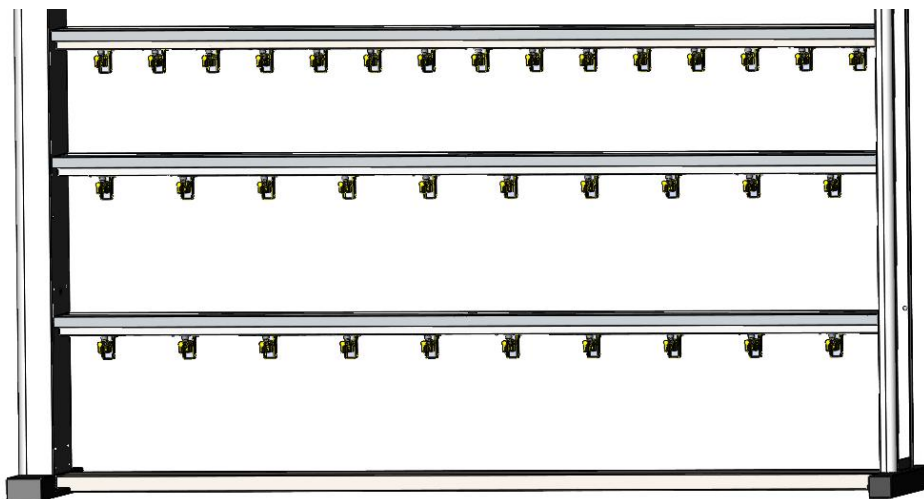

5.6. 连接轴安装：打开架板的搁板，将连接轴带有圆点凸台端向左插入到左侧板电机内，（注：需要对齐开槽面插入）向左继续压缩弹簧，使其能套到右边的转轴上，必须保证右边的开槽能卡到销子上。同理将上面每层架板都装上连接轴

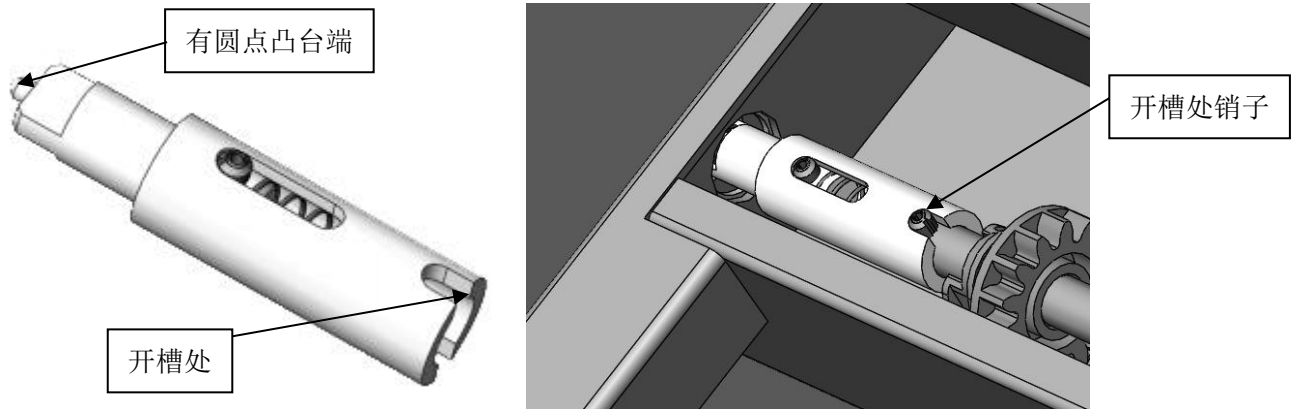

5.7. 装饰板安装：将装饰板上的后开槽对齐定位螺丝内，下压到位。

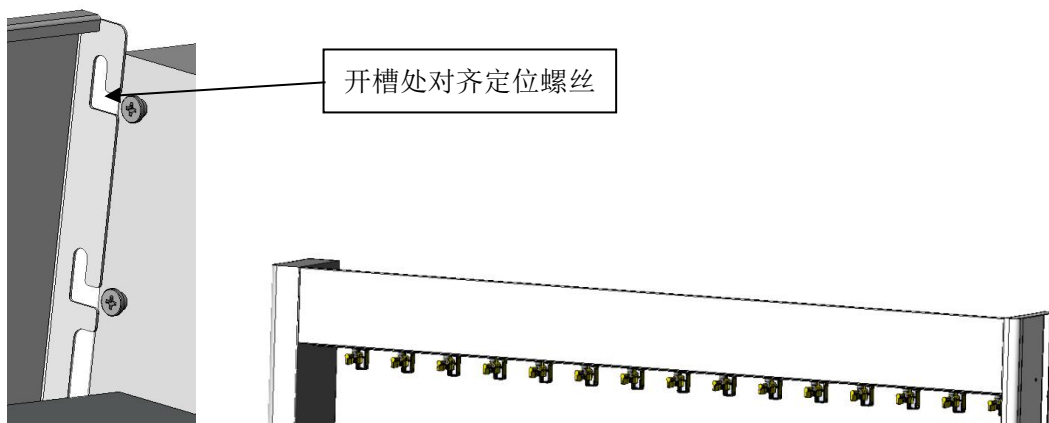

5.8. 利用扳手按图示安装拉紧条。旋转两个花兰调紧拉紧条，使设备端正稳定。

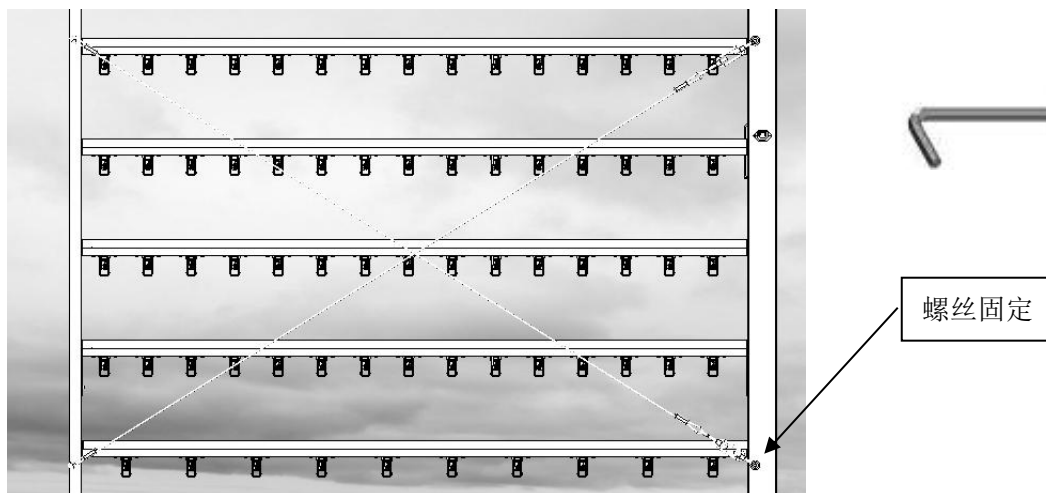

5.9. 台板安装，如有台板，将左右固定板固定在第二层架板下面的左右侧板上，先不要拧紧螺钉，再将台板安装在左右固定板上并拧紧螺钉。注意台板架板的安装位置一般为第二层。

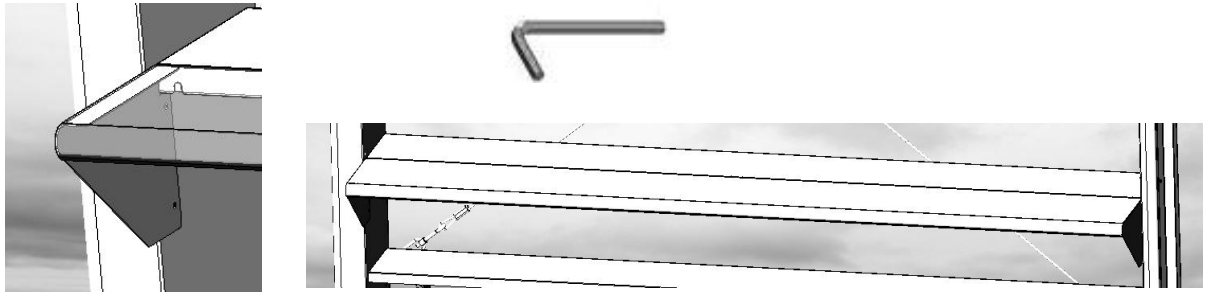

5.10. 开关盒安装，将开关盒座板上下 2 个安装孔对齐左侧板前面以安装好的 M6 螺丝，开关盒座板上下的孔的对齐螺帽放进去后向左旋转，旋转到位后用扳手固定牢固。将开关盒上的品字插头（母头）插入搅拌机左侧板背后的公头上，将插头插接在电源插座上。

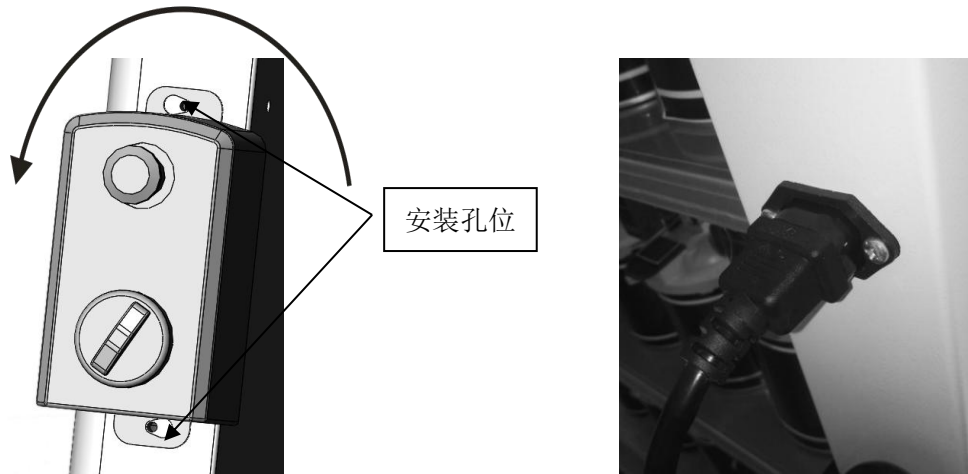

5.11. 拉下塑料定位卡，使塑料定位卡卡住架板槽中，会听到“咔吧”声为止。

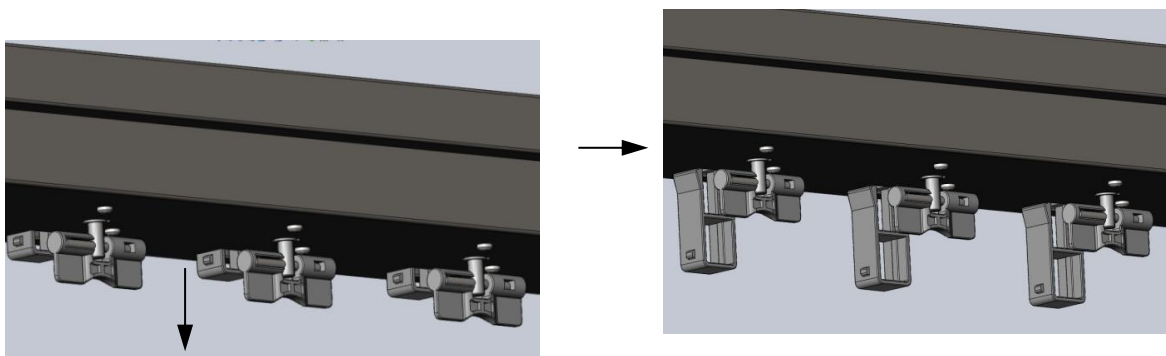

至此设备安装完成。

6. 试机

1. 接通电源，合上设备上开关盒侧面的断路器。
2. 转动定时器旋钮，设定运转时间。最长时间为 15 分钟。到达设定的时间后，设备自动停止转动。若想中途停机，可逆时针转动时间继电器至 OFF 位置，则机器停止运行。注意：如果设备有异常声音，应立即按下急停开关，设备会立刻停止工作。排除设备异常后，如箭头所示顺时针旋转急停开关，设备就会接通电源。



7. 使用

注意：油漆桶在放入设备前必须进行充分地搅拌。

漆桶放到搅拌机上时，将浆盖上的定位套（如图）对准插入塑料定位卡中。

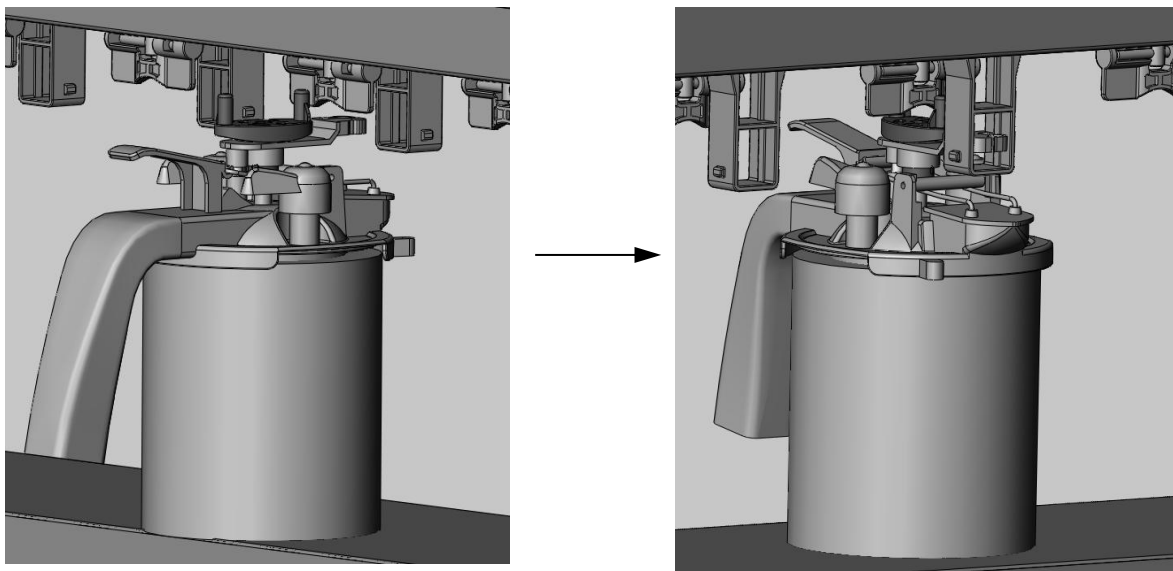

每天按您设定的时间转动定时器旋钮，设备就可以正常工作了。

8. 故障排除

故障描述	原因	排除方法
电机不转 或带不动	没有电源输入	检查电源插座、电源线，确保开关盒有输入电压。
	插头松动	打开左侧板盖板，重新插一下插头。
	小型断路器断开	推上小型断路器。
	电压过低	测试电压是否在 110 或 230V \pm 5%之间，超过范围需自备稳压器。
	适配器损坏	拆除坏适配器，安装新适配器，插上接头即可。
	电机损坏	拆除坏电机，安装新电机，插上插座即可。
	急停开关没有打开	顺时针旋转急停开关，即可接通电源。
电机转动，架体不转	层连接轴脱落	揭开搁板，观看层连接轴是否到位，调整到位即可

⚠ 上述所有维修工作必须首先停机并拔掉电源线，严禁未拔掉插头或运转时进行维修！

Zhengzhou Sanhui Machinery & Equipment Co., Ltd.

郑州三惠机械设备有限公司

Add: Zhengzhou, Henan, P.R.China

地址: 河南省郑州市高新区电子电器产品园

TEL: 86-371-67575169

FAX: 86-371-61107058

Website: www.sinotint.com

电话: 0371-67575168

传真: 0371-61107058

网址: www.sinotint.com
